

# Polymak

## ANGLE GRINDER

125mm

INSTRUCTION MANUAL



Read and follow all safety precautions in instruction manual.

# Polymak

Polymak Tools(India) Pvt. Ltd  
186/187, P.H Road,Alsa Towers,Kilpauk,  
Chennai – 600 010,  
Tel. : +91-44-48631869  
E-mail : info@polymak.co.in  
Visit us at : www.polymak.co.in

### SAFETY INSTRUCTIONS

- WARNING!** Read all instructions. Failure to follow all instructions listed below may result in electric shock, fire and/or serious injury. **SAVE THESE INSTRUCTIONS**
- Work area**
    - Keep work area clean and well lit. Cluttered and dark areas invite accidents.
    - Do not operate power tools in explosive atmospheres, such as in the presence of amenable liquids, gases or dust. Power tools create sparks which may ignite the dust or fumes.
    - Keep children and bystanders away while operating a power tool. Distractions can cause you to lose control.
  - Electrical safety**
    - Power tool plugs must match the outlet. Never modify the plug in any way. Do not use any adapter plugs with earthed (grounded) power tools. Unmodified plugs and matching outlets will reduce risk of electric shock.
    - Avoid body contact with earthed or grounded surfaces such as pipes, radiators, ranges and refrigerators. There is an increased risk of electric shock if your body is earthed or grounded.
    - Do not expose power tools to rain or wet conditions. Water entering a power tool will increase the risk of electric shock.
    - Do not abuse the cord. Never use the cord for carrying, pulling or unplugging the power tool. Keep cord away from heat, oil, sharp edges or moving parts. Damaged or entangled cords increase the risk of electric shock.
    - When operating a power tool outdoors, use an extension cord suitable for outdoor use. Use of a cord suitable for outdoor use reduces the risk of electric shock.
    - Use a Residual Circuit Breaker on all 220-240V Power tools. This can help minimize the risk of an electrical shock if an earth fault or short circuit occurs.
    - If using a power cable extension ensure that the cable is fully unwound and that its length is less than 30m. Lengths over 30 m will affect the tool's performance as a result of voltage drop.
  - Personal safety**
    - Stay alert, watch what you are doing and use common sense when operating a power tool. Do not use a power tool while you are tired or under the influence of drugs, alcohol or medication. A moment of inattention while operating power tools may result in serious personal injury.
    - Use safety equipment. Always wear eye protection. Safety equipment such as dust mask, non-skid safety shoes, hard hat, or hearing protection used for appropriate conditions will reduce personal injuries.
    - Avoid accidental starting. Ensure the switch is in the off-position before plugging in. Carrying power tools with your finger on the switch or plugging in power tools that have the switch on invites accidents.
    - Remove any adjusting key or wrench before turning the power tool on. A wrench or a key left attached to a rotating part of the power tool may result in personal injury.

1

- Do not overreach. Keep proper footing and balance at all times. This enables better control of the power tool in unexpected situations.
  - Dress properly. Do not wear loose clothing or jewellery. Keep your hair, clothing and gloves away from moving parts. Loose clothes, jewellery or long hair can be caught in moving parts.
  - If devices are provided for the connection of dust extraction and collection facilities, ensure these are connected and properly used. Use of these devices can reduce dust-related hazards.
- Power tool use and care**
    - Do not force the power tool. Use the correct power tool for your application. The correct power tool will do the job better and safer at the rate for which it was designed.
    - Do not use the power tool if the switch does not turn it on and off. Any power tool that cannot be controlled with the switch is dangerous and must be repaired.
    - Disconnect the plug from the power source before making any adjustments, changing accessories, or storing power tools. Such preventive safety measures reduce the risk of starting the power tool accidentally.
    - Store idle power tools out of the reach of children and do not allow persons unfamiliar with the power tool or these instructions to operate the power tool. Power tools are dangerous in the hands of untrained users.
    - Maintain power tools. Check for misalignment or binding of moving parts, breakage of parts and any other condition that may affect the power tools operation. If damaged, have the power tool repaired before use.
    - Keep cutting tools sharp and clean. Properly maintained cutting tools with sharp cutting edges are less likely to bind and are easier to control.
    - Use the power tool, accessories and tool bits etc., in accordance with these instructions and in the manner intended for the particular type of power tool, taking into account the working conditions and the work to be performed. Use of the power tool for operations different from intended could result in a hazardous situation.
  - Service**
    - Have your power tool serviced by a qualified repair person using only identical replacement parts. This will ensure that the safety of the power tool is maintained.

### HEALTH ADVICE

- WARNING!** When drilling, sanding, sawing or grinding, dust particles will be produced. In some instances, depending on the materials you are working with, this dust can be particularly harmful to you (e.g., lead from old gloss paint). You are advised to consider the risks associated with the materials you are working with and to reduce the risk of exposure. You should:
- Work in a well-ventilated area.
  - Work with approved safety equipment, such as those dust masks that are specially designed to filter microscopic particles.

2

### ADDITIONAL SAFETY INSTRUCTIONS FOR YOUR ANGLE GRINDER

- If the supply cord is damaged have it replaced by a qualified person.
- Check that speed marked on the wheel is equal to or greater than the rated speed of the grinder.
- Ensure that the wheel dimensions are compatible with the grinder.
- Abrasive wheels shall be stored and handled with care in accordance with manufacturer's instructions.
- Inspect the grinder wheel before use. Do not use chipped, cracked or otherwise defective products.
- Ensure that mounted wheels/discs and parts are fitted in accordance with the manufacturer's instructions.
- Ensure that the abrasive product is correctly mounted and tightened before use and run the tool at no-load for 30 seconds in a safe position. Stop immediately if there is considerable vibration or if other defects are detected. If this condition occurs, check the machine to determine the cause.
- If a guard is supplied with the tool never use the tool without such a guard.
- Do not use separate reducing bushings or adapters to adapt large hole abrasive wheels.
- For tools intended to be fitted with a threaded hole, ensure that the thread in the wheel is long enough to accept the spindle length.
- Check that the work piece is properly supported.
- Do not use out of wheel for side grinding.
- Ensure that sparks resulting from use do not create a hazard e.g. do not hit persons, or igniteammable substances.
- Ensure that ventilation openings are kept clear when working in dusty conditions. If it should become necessary to clear dust, first disconnect the tool from the mains supply (use non metallic objects) and avoid damaging internal parts.
- For cleaning, always use eye and ear protection. Other personal protective equipment such as dust mask, gloves, helmet and apron should be worn.
- The wheel continues to rotate after the tool is switched off.
- Always check walls to avoid hidden power cables and pipes.
- Do not touch the workpiece immediately after grinding as it will be very hot.
- Do not hold unsecured work in your hand.
- Do not use the grinder as a fixed tool.
- Do not try to cool the grinding disc with water.
- Always use the appropriate safety equipment that is required for the product, e.g. Goggles / Safety Spectacles, Ear defenders (essential with tools with a noise rating of over 85 dbA), Gloves and face masks. In all cases ensure that the safety equipment is in good condition.
- Ensure that if a side handle or stabilising handle is provided with the power tool then these are adjusted into a comfortable position and that both handles are used to securely grip the power tool when in use.

3

### Double insulation:

The tool is double insulated. This means that all the external metal parts are electrically insulated from the mains power supply. This is done by placing insulation barriers between the electrical and mechanical components making it unnecessary for the tool to be earthed.

### Important note

Remove the mains plug from socket before carrying out any adjustment or servicing. Ensure your mains supply voltage is the same as your tool rating plate voltage.

### SYMBOLS



### TECHNICAL DATA

Model No.	PMAG5-1000S
Rated power input:	1000w
Rated voltage:	220v
No load speed:	11000r/min
Disc diameter:	125mm
Double insulation:	<input checked="" type="checkbox"/>

4

### OPERATION INSTRUCTIONS

**WARNING!** Before using your angle grinder be sure to read the instruction manual carefully.



Fig 1



Fig 2

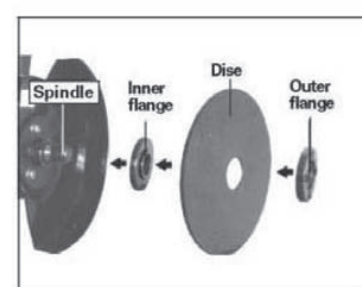

Fig 3

- INSTALLING THE AUXILIARY HANDLE** (see fig 1)  
An auxiliary handle is supplied and can be fixed into both of the two positions on the gearcase. If you are right handed fit the handle as shown in fig1. If you are left handed fit the handle the other way round. When using a cutting disc, you can screw the handle into the position on top of the gearcase.  
**NOTE:** This handle should be used at all times to maintain complete control of the tool.
- ADJUSTING WHEEL GUARD** (see fig 2)  
Adjust the guard to protect your hands and direct grinding debris. Loosen the screw. Position the guard at the required angle. Then tighten the screw.  
**CAUTION:** Be sure that the guard is secure before starting the angle grinder.  
**WARNING:** Never use the angle grinder without the disc guard in place.
- FITTING THE DISCS** (see fig 3)  
Place the grinding/cutting disc on top of the inner flange and over the spindle. Ensure that it is firmly located on the raised section of the inner flange. See fig3. Locate the outer flange over the disc, making sure that the raised side is facing the disc and is fully located in the centre hole of the disc.  
**NOTE:** When clamping this section metal diamond discs, the outer flange must be reversed so that the full depth side screws against the disc hub.  
Press and hold down the spindle lock button and tighten the outer flange using the two pin locking wrench. It may be necessary to turn the spindle to fully locate the spindle lock button.  
When the outer flange washer is tight, release the spindle lock button and remove the wrench.

5

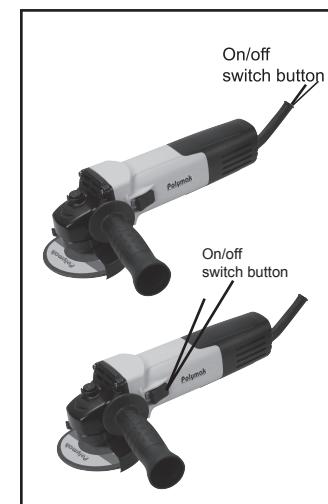

Fig 4



Fig 5

- SWITCH** (see fig 4)  
The On/Off trigger switch is spring in the OFF position. The angle grinder is started by pushing forward the on/off switch. See fig 4. To stop the angle grinder, release the on/off switch and it will return to the OFF position.  
**WARNING!** The disc will continue rotate for a few seconds after the angle grinder has been switched off.  
Always wait until the disc has stopped completely before putting the angle grinder down. Do not attempt to operate the spindle lock button while the disc is still rotating.
- TO USE GRINDER** (see fig 5)  
Attention: Do not switch the grinder on whilst the disc is in contact with the workpiece. Allow the disc to reach full speed before starting to grind. Hold your angle grinder with one hand on the main handle and other hand firmly around the auxiliary handle.  
Always position the guard so that as much of the exposed disc as possible is pointing away from you.  
Be prepared for a stream of sparks when the disc touches the metal.  
For best tool control, material removal and minimum overloading, maintain an angle between the disc and work surface of approximately 15°-30° when grinding and 10°-15° when sanding. Exert light pressure on abrasive discs for efficient operation. Pushing too hard will cause a drop in speed and may result in motor overload and damage.  
Use caution when working into corners as contact with the intersecting surface may cause the grinder to jump or twist.  
When grinding is complete allow the workpiece to cool. Do not touch the hot surface.
- OVERLOAD**  
Overloading will cause damage to the motor of your angle grinder. This can happen if your angle grinder is subjected to heavy use for prolonged periods of time.  
Do not in any circumstances, attempt to exert too much pressure on your angle grinder to speed up your work.

6

The abrasive discs operate more efficiently when light pressure is exerted, thus avoiding a drop in the speed of your angle grinder. If your angle grinder becomes too hot, run your angle grinder under no load for 2-3 minutes until it has cooled to normal operation temperature.

### WORKING HINTS FOR YOUR ANGLE GRINDER

- Your angle grinder is useful for both cutting through metals, as for removing screw heads, and also for cleaning / preparing surfaces, before and after welding operations.
- Different types of wheel/outer will allow the grinder to meet various needs. Typically, grinding wheels/cutting discs are available for mild steel, stainless steel, stone and brick. Diamond impregnated discs are available for very hard materials.
- If the grinder is used on soft metals such as aluminum the wheel will soon clog and will have to be changed.
- At all times, let the grinder do the work, do not force it or apply excessive pressure to the wheel/disc.
- If cutting a slot ensure that the cutter is kept aligned with the slot, twisting the cutter may cause the disc to shatter. If cutting through this sheet, only allow the cutter to just project through the material, excessive penetration can increase the chance of causing damage.
- If cutting stone or brick, it is advisable to use a dust extractor.

### MAINTENANCE

- WARNING!** Ensure the grinder is disconnected from the mains power supply before attempting any maintenance.
- Keep the grinder ventilation slots clean and free from obstructions. If available, blow compressed air into the vents to clear any internal dust (safety goggles must be worn when undertaking this process).
  - Keep the outer case of the grinder clean and free from grease. Do not wash with water or use solvents or abrasives. Use only mild soap and a damp cloth to clean the tool. Never let any liquid get inside the tool. Never immerse any part of the tool into a liquid.
  - Your angle grinder requires no additional lubrication. There are no user serviceable parts in your power tool.
  - Always store your power tool in a dry place.
  - If you see some sparks flashing in the ventilation slots, this normal and will not damage your power tool.

### TROUBLESHOOTING

- Although your new angle grinder is really very simple to operate, if you do experience problems, please check the following:
- If your grinder will not operate, check the power at the mains plug.
  - If your grinder wheel wobbles or vibrates, check that outer flange is tight, check that the wheel is correctly located on the flange plate.
  - If there is any evidence that the wheel is damaged, do not use as the damaged wheel may disintegrate, remove it and replace with a new wheel. Dispose of old wheels sensibly.
  - If working on aluminum or a similar soft alloy, the wheel will soon become clogged and will not grind effectively.

### ENVIRONMENTAL PROTECTION

- Waste electrical products should not be disposed of with household waste. Please recycle where facilities exist. Check with your Local Authority or retailer for recycling advice.

7

### Model No: PMAG5-1000S

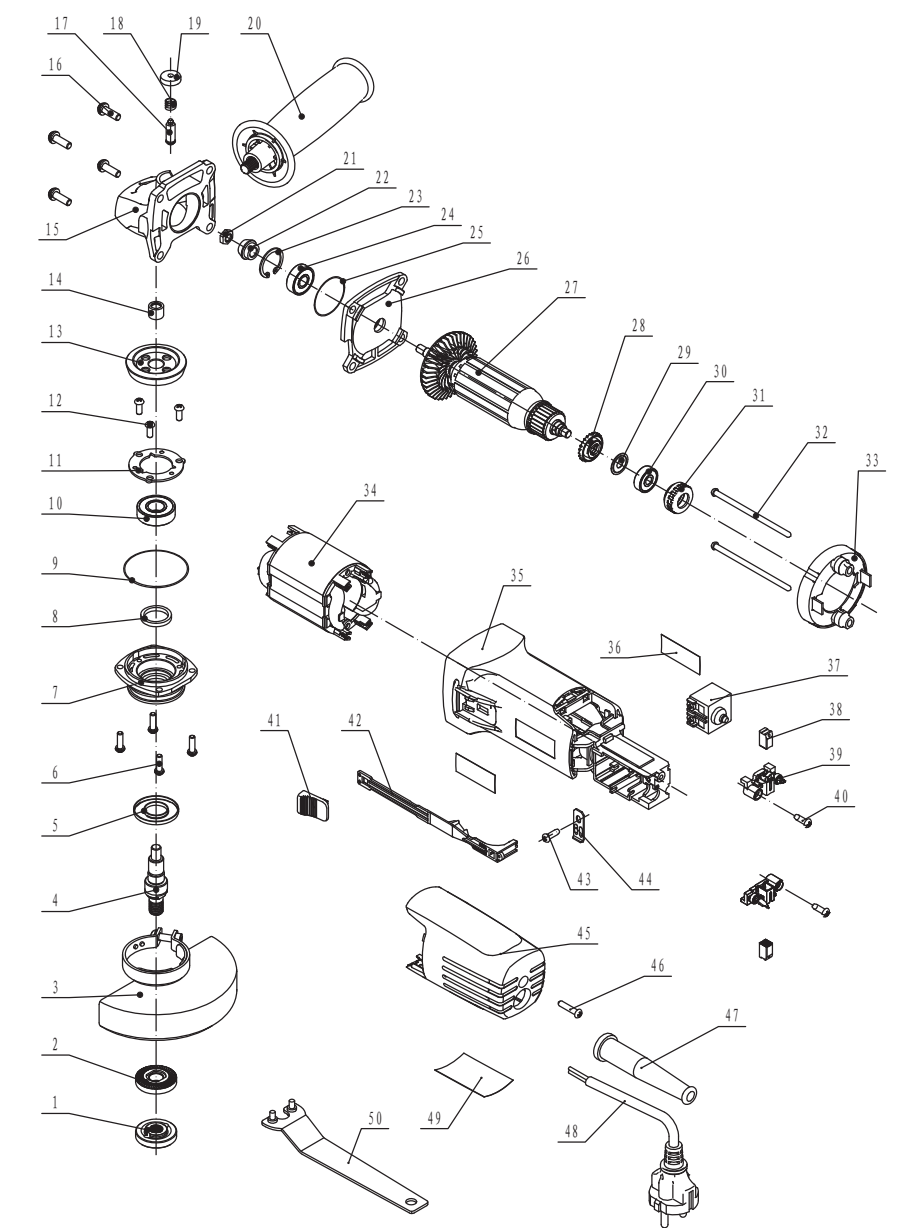

8

### PMAG5-1000S Spare part list

No	Description	QTY	No	Description	QTY
1	inner flange	1	26	middle plate	1
2	outer flange	1	27	armature	1
3	wheel guard	1	28	dustproof ring	1
4	shaft	1	29	spacer	1
5	dustproof cover	1	30	bearing 626	1
6	screw M4x13	4	31	bearing sleeve	1
7	front cover	1	32	screw ST4x75	1
8	wool ring	1	33	windshield	1
9	ring	1	34	stator	1
10	6001 bearing	1	35	housing	1
11	bearing cover	1	36	brand	1
12	screw M4x10	3	37	switch	1
13	gear wheel	1	38	carbon brush	2
14	needle bearing	1	39	brush box	2
15	gear box	1	40	screw ST4x12	2
16	screw ST5x25	4	41	Pushing block	2
17	selflock pin	1	42	Pushing rod	1
18	spring	1	43	screw ST4x14	1
19	selflock pin cap	1	44	Pressing line plate	1
20	side hangle	1	45	rear cover	1
21	nut	1	46	screw ST4x12	2
22	pinion	1	47	cabie protector	1
23	circlip for hole	1	48	cabie	1
24	bearing 608	1	49	brand	1
25	circlip Ø29.4*0.75	1	50	wrench	1

9