

Polymak

Polymak Tools(India)Pvt.Ltd

186/187,P.H Road,Alsa Towers,Kilpauk,
Chennai-600 010,

Tel. :+91-44-48631869

E-mail :info@polymak.co.in

Visit us at:www.polymak.co.in

Polymak

MITER SAW

INSTRUCTION MANUAL

PM255BMS-DY



Read and follow all safety precautions in instruction manual

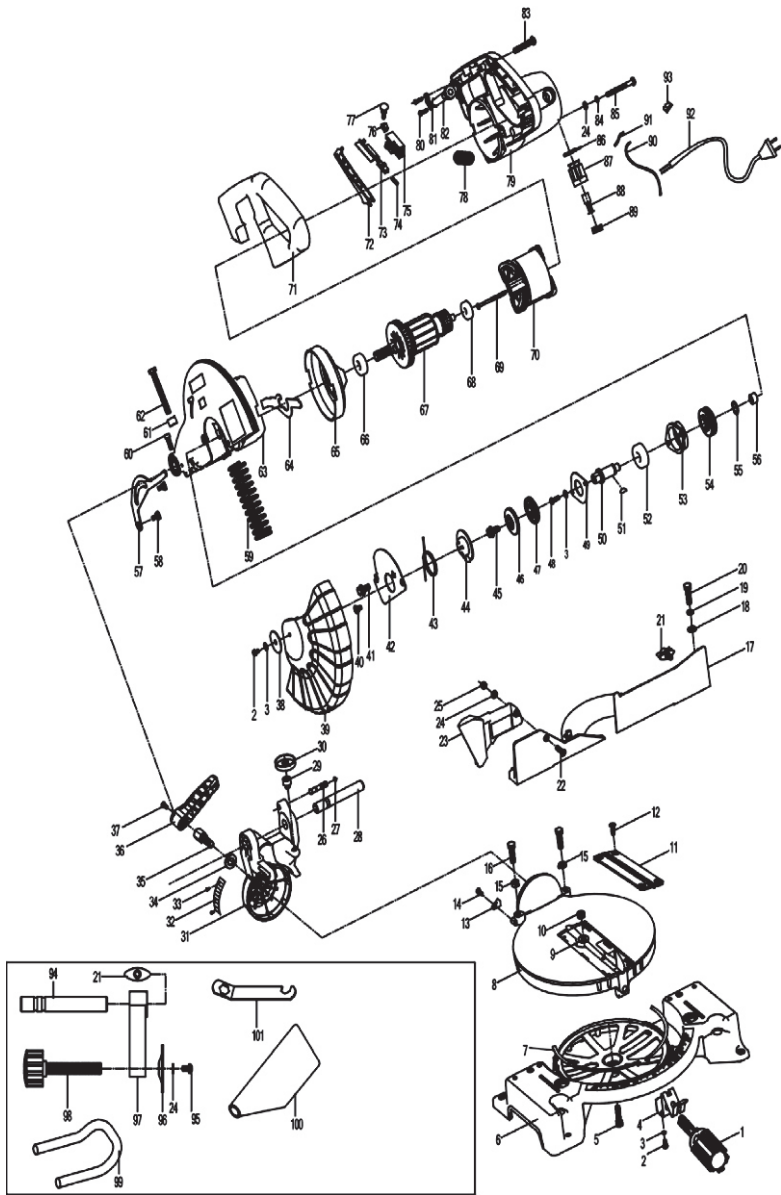

•HANDING OF THE TOOL

Before handing of the machine, secure the handle at its lowest position with the locking pin, and secure the rotary table by turning the rotary table handle. Then, the tool can be carried conveniently by the handling grip.

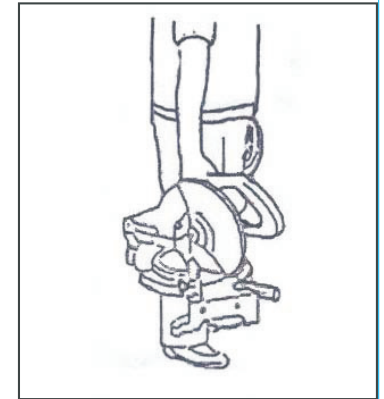

●CHANGING SAWBLADE

To remove the sawblade,loosen the bolt which fix the central cover by turning it counterclockwise using the socket wrench provided.Then,raise the central cover and move it down from the original position.

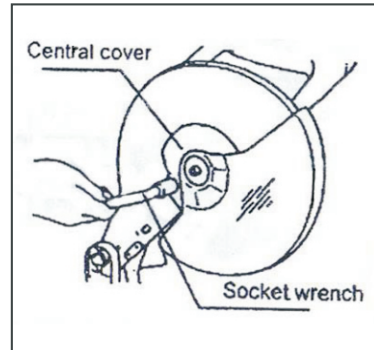

When removing sawblade,first raise the lowest position handle,press down the shaft locking arm to lock the sawblade,and loosen the hex bolt by turning clockwise using the socket wrench.Then,remove the hex bolt outer flange and sawblade.

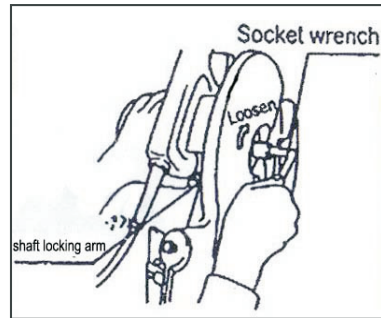

Install the new sawblade.Check that the teeth point in the direction of the arrow(See the protective cover).

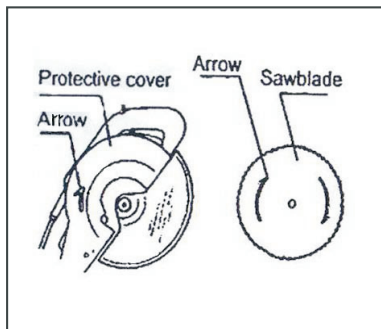

SPARE PARTS LIST

NO.	SPE.	NO.	SPE.	NO.	SPE.
1	ANGLE JUST	34	FLAT WASHER φ2.3	68	BEARING 6000Z
2	SCREW M5X12	35	SCREW NUT M10X30	69	SCREW ST6X65
3	WAVE WASHER φ5	36	HANDLE	70	STATOR
4	DEGREE MARK	37	SCREW NUT M4X12	71	HANDLE COVER
5	SCREW NUT M8X30	38	FLAT WASHER φ5	72	BUTTON OF SWITCH
6	BASE	39	COVER	73	SLIP SHEET OF SWITCH
7	SLIP RUBBER	40	SCREW NUT M6X8	74	SPRING OF SWITCH
8	BASE PLATE	41	SCREW M6X14	75	SWITCH
9	FLAT WASHER	42	FIXING FLANGE	76	BUTTON OF SLIP SHEET
10	SCREW NUT M8	43	SPRING	77	BUTTON OF AUTO-LOCK
11	NUT ON BASE	44	COVER FALNGE	78	HOUSING
12	SCREW M4X10	45	SCREW NUT M8X16	79	SPRING OF AUTO-LOCK
13	GUIDE	46	OUTSIDE FLANGE	80	SCREW ST4X16
14	SCREW NUT M4X10	47	INSIDE FALNGE	81	FLAT OF CABLE
15	SCREW NUT M8	48	FRONT FLANGE	82	PROTECT OF CABLE
16	SCREW NUT M8X20	49	SCREW NUT M5X14	83	SCREW ST4X16
17	CROSS BAR	50	SPINDLE	84	WAVE WASHER φ6
18	FLAT WASHER φ8	51	KEY	85	SCREW NUT M6X60
19	WAVE WASHER φ8	52	BEARING 6203	86	SPRING
20	SCREW NUT M8X25	53	FRONT COVER	87	BRUSH HOUSING
21	SCREW NUT M6X14	54	GEAR	88	BRUSH
22	SCREW NUT M6X25	55	OUCH	89	BRUSH COVER
23	SMALL GUARD	56	NEEDLE BEARING	90	COLLECT COVER
24	FLAT WASHER φ6	57	COUPLER	91	TERMINAL OF STATOR
25	SCREW NUT M6	58	SCREW NUT M6X8	92	CORD WIRE
26	CROSS PIN	59	SPRING	93	COLLECT NUT
27	"O" RING	60	SCREW NUT M6X20	94	STRAIGHT PIN
28	SHAFT OF BRAKET	61	RUBBER COVER	95	SCREW NUT M5x8
29	SPING BRAKET	62	SCREW NUT M8X75	96	DUMMY WAFER
30	"U" SPRING WASHER	63	BLADE COVER	97	COUPLER
31	BRAKET	64	AUTO-LOCK SHEET	98	SCREW NUT M10X70
32	RULE	65	BAFFUL	99	LONG POLE
33	SCREW φ2.3	66	BEARING 6202RS	100	BAG
		67	ARMATURE	101	SPANNER

Replacing the carbon brushes

Check and remove the carbon brushes regularly. Replace when they wear down to the limit mark. Keep the carbon brushes clean and free to slip in the holders. Both carbon brushes should be replaced at the same time.

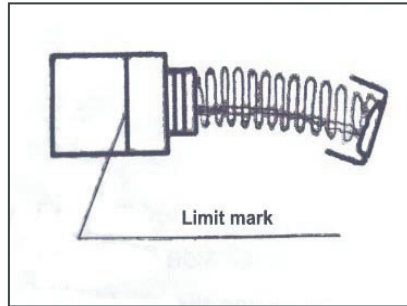

Use a screwdriver to remove the brush holder caps. Take out the worn carbon brushes, insert the new ones and secure the brush holder caps.

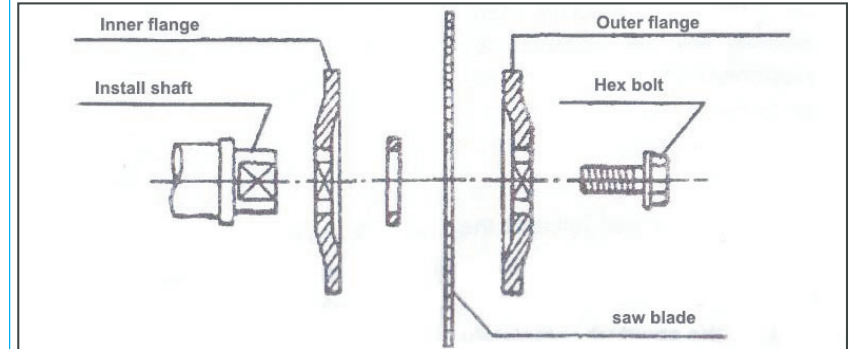
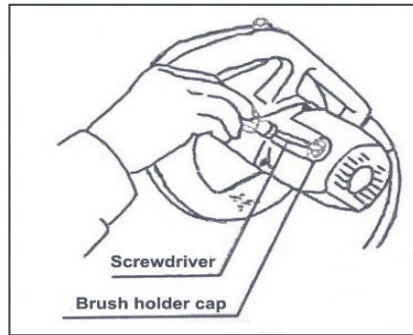

Install the outer flange and the hex bolt. Then, press down the shaft locking arm, and tighten the hex bolt firmly by turning it counterclockwise using the socket wrench, then adjust the hex bolt in clockwise so as to fix the central cover.

When removing sawblade, lift up movable hood and central cover, loosen the hex bolt with the socket wrench, then remove the hex bolt, outer flange and sawblade.

•MOVABLE HOOD

When sawing, the movable hood will be lifted up by the workpiece. After you finish cutting, the movable hood will be reset to original position automatically with the handle raised. Never abandon or remove the movable hood.

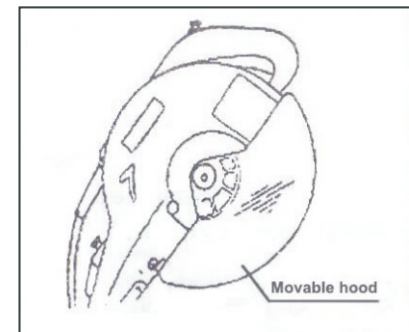
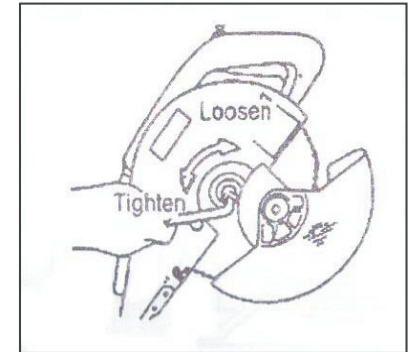

•SAWDUST COLLECTOR

You can operate this machine more conveniently with the sawdust collector. Connect the adapter of the collector to the nozzle of the protective cover. Then, fix the collector inlet to the adapter of the collector. When the sawdust collector is half full, take the collector off from the protective cover and open the collector door at the bottom. Clean the sawdust completely.

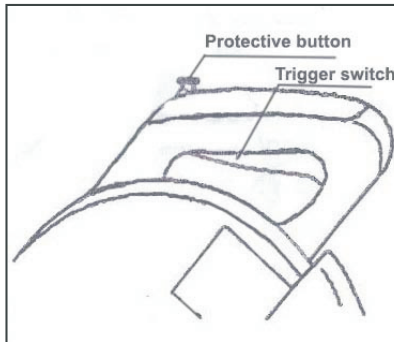
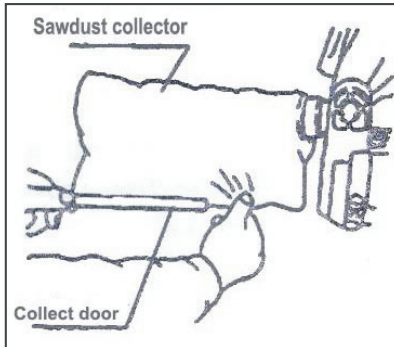
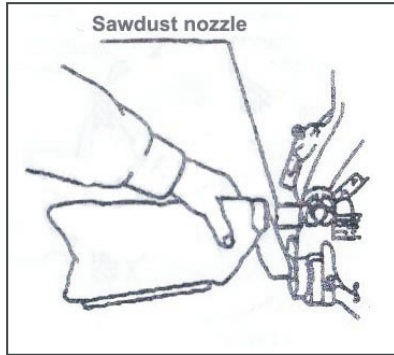

•OPERATING THE SWITCH

To prevent accidental starting, the tool is equipped with a protective switch. To start the tool, you should first press the protective switch and press down the trigger switch. Release the trigger switch, the tool is switched off.

1. Bevelled joint cutting
refer to the part of "SET A BEVELLED JOINT ANGLE"
2. Beveling cutting
Tilt the machine to the left, the machine can make cuts at 0°~45°
Shown as the drawing, fix the auxiliary stopper on the left side. Loosen the fixed handle and incline the sawblade to the desired angle, then fix the workpiece with the vice. Switch the machine on and wait till the sawblade reaches its maximum speed. Then press the handle downwards slowly. After you have finished cutting, switch the machine off and wait until the sawblade stops completely, then raise the sawblade to its highest position.

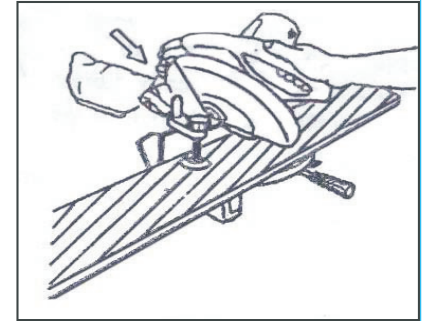

3. Composite cutting
You can make composite cuts as the following table.

Beveling cutting angle	Bevelled joint cutting angle
45°	On left and right side at 0°~45°

When making composite cutting, you can refer to the instructions of "Bevelled joint cutting" and "Beveling cutting".

•OPERATING

When you make cuts,a piece of work-piece(which thickness is same as the thickness of sawblade)will be cut out,so the cut line should be set on the left side or right side of the auxiliary block slot.Switch the machine on ,and wait till the sawblade reach its maximum speed.Then,press the handle downwards slowly.As soon as the sawblade comes into contact with the workpiece,press the handle downwards evenly to begin the cut.After you have finished cutting,wait until the sawblade stops completely.Because the cutting chips may be ejected by the rotating sawblade to make accidents.

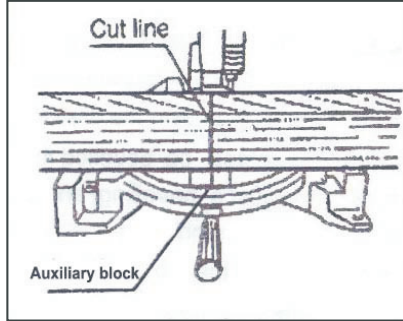

•AUXILIARY STOPPER

The tool is attached an auxiliary stopper,in normally condition,it is set as shown the drawing.But when the tool is used to make bevel cuts on the left,it should be installed on the left side(shown as the drawing)

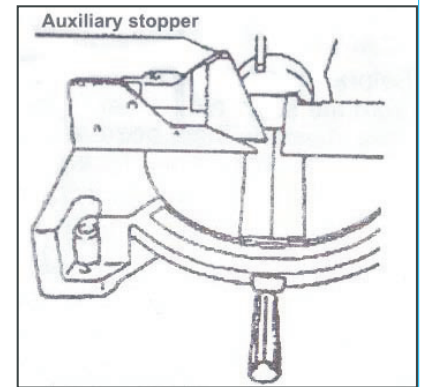
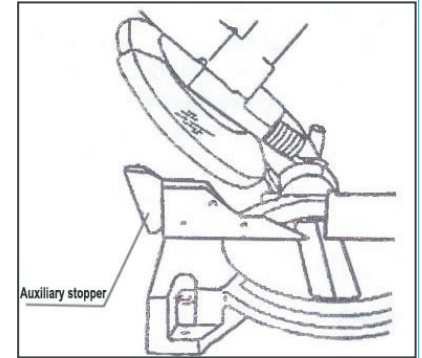

•KEEP THE MAXIMUM CUTTING CAPACITY

Before any adjusting,remove the plug from the socket.

This machine has been adjusted by the manufacturer to keep the maximum cutting capacity using a 260mm(10-7/32)sawblade. When the diameter of the sawblade becomes smaller because of grinding, loosen the adjusting bolt at the rear of the handle so as to adjust the adjusting bolt. Turning the adjusting bolt counterclockwise you can lower the sawblade. Turning it clockwise, you can raise the sawblade. When you have adjusted the handle to its lowest position permitted, the distance between the front surface of the stop strip and the cutting edge of the saw blade is 135mm(5-5/16"). After removing the plug from the socket, turn the sawblade with a hand and press down the handle with another hand all the while so as to make sure the sawblade doesn't contact any position of the base when the handle is lowered to its lowest position permitted.

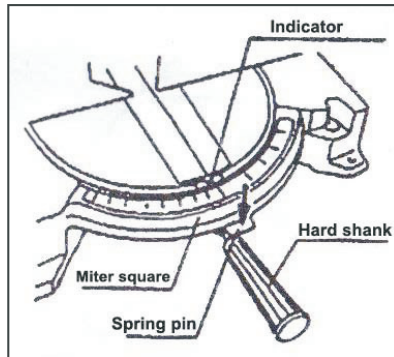
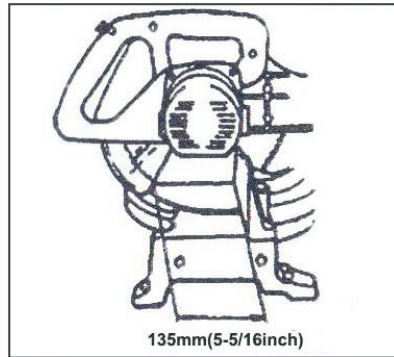
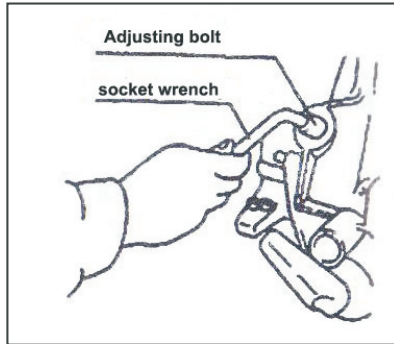

•SET A BEVELLED JOINT ANGLE

Loosen the hand shank by turning it in counterclockwise, press down the spring pin so that the rotary table is free to turn. When the desired angle on the scale on the base matches up with the arrow marked on the rotary table turn the hand shank clockwise to tighten it.

•SET A BEVELLING ANGLE

Only when the auxiliary stopper is fixed on the left side as shown the drawing, the sawblade can be bevelled 45° angle. To adjust a beveling angle, loosen the fixed handle, then incline the sawblade to the left until the indicator reaches the desired angle on the miter square, tighten the fixed handle firmly.

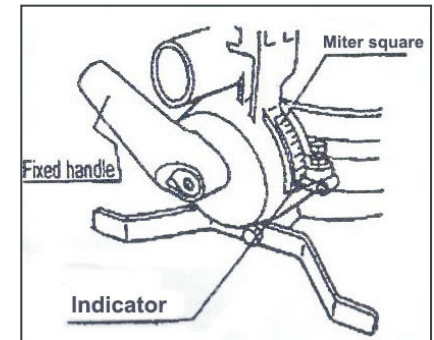
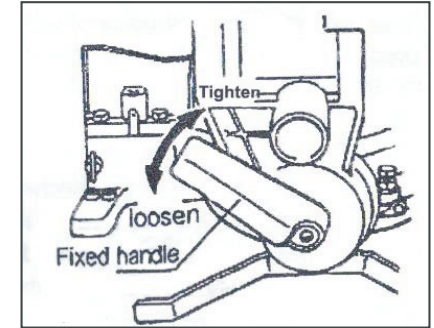

•SECURE WORKPIECE

The vertical vice can be installed in hole of the guide bar or the workpiece supporter component (selective purchasing). Install the vice rod in the hole of the guide bar or workpiece supporter component, then tighten the bolt. You should adjust the position of the vice arm according to the thickness and shape of the workpiece and tighten the vice arm with bolt. Lean the workpiece against the guide bar and the rotary table, and place the workpiece on the desired cutting position. Then tighten the clamp bolt so as to secure the workpiece.

