

Polymak®

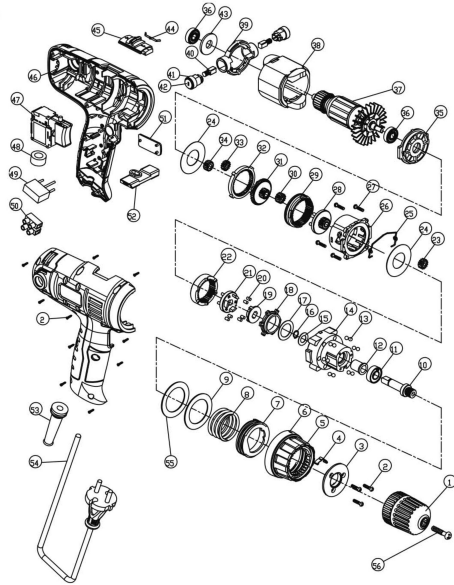

PM10TD ELECTRIC DRILL
 Chuck Size: 10mm
 No load speed: 0-750r/min
 Power: 280W
 Net weight: 0.9KG



www.polymak.co.in

Polymak®

PM10TD SPARE PARTS LIST

No	Parts Name	Pcs	Seri No	INR	No	Parts Name	Pcs	Seri No	INR
1	10mm type chuck	1			38	Stator	3		
2	Screw	1			39	Carbon brush holder	1		
3	Clamp of adjustment plate	1			40	Carbon brush	1		
4	Positioning reed	1			41	Brush holder	1		
5	Adjustment Plate	1			42	Brush cap	1		
6	Outer ring of adjustment plate	1			43	Insulating barrier	1		
7	Internal screw sleeve	1			44	Speed reed	1		
8	Big spring	1			45	Speed push button	1		
9	Spacer	1			46	Enclosure	1		
10	Spindle	1			47	Switch	1		
11	Deep groove ball bearing	2			48	Magnet ring	1		
12	Shaft sleeve	1			49	Capacitance	1		
13	Steel ball	1			50	Binding post	1		
14	Gear case	1			51	Decorative sheet	2		
15	Spacer	4			52	Direction setting button	1		
16	Wild spring	5			53	Cable shield	1		
17	Spacer	5			54	VED plug cord	1		
18	Fixed ring	3			55	Spacer	1		
19	Driving disc	2			56	Clamp head screw	1		
20	Kingpin	2							
21	Level 3 planet carrier	2							
22	Inner gear ring	1							
23	Level 3 planet gear	1							
24	Clamp	2							
25	Hook	1							
26	Speed changing box	1							
27	Galvanized	1							
28	Level 2 planet carrier	1							
29	Dynamic gear ring	1							
30	Level 2 planetary gear	1							
31	Level 2 planet carrier	1							
32	Fixed gear ring	1							
33	Level 1 planetary gear	1							
34	Motor gear	1							
35	Motor fange	1							
36	Deep groove ball bearing	1							
37	Rotor	1							