

Polymak®

PM10DM-HD

ELECTRIC DRILL

Chuck capacity: 10mm
 No load speed: 0-3400r/min
 Power: 710W
 Weight: 1.9kg

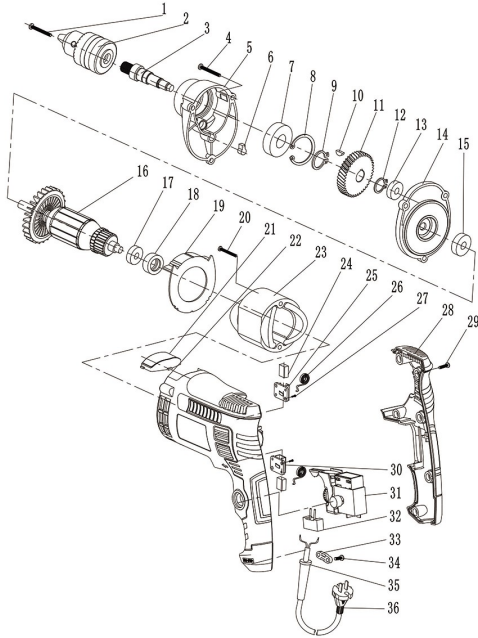

www.polymak.co.in

Polymak®

PM10DM-HD SPARE PARTS LIST

No	Parts Name	Pcs	INR
1	BoltM5X 18(left)	1	
2	Drill chuck	1	
3	Output shaft	1	
4	BoltST4X 22	3	
5	Head capsule	1	
6	Wool felt	1	
7	Bearing 6002	1	
8	Circlip for shaft 32	1	
9	Circlip for shaft 15	1	
10	Woodruff key3X 3.7X 10	1	
11	Rack wheel	1	
12	Circlip for shaft 12	1	
13	Bearing 698	1	
14	Middle cover	1	
15	Bearing 609	1	
16	Rotor	1	
17	Bearing 607	1	
18	Bearing bush	1	
19	Break wind ring	1	
20	BoltST4X 50	2	
21	Overlay	1	
22	Chassis	1	
23	Stator	1	
24	Cables heath	2	
25	Brush carrier(up)	1	
26	Coil spring	2	
27	BoltST3X 10	4	
28	Handle cover	1	
29	BoltST4X 14	6	
30	Brush carrier(down)	1	
31	Switch	1	
32	Capacity	1	
33	Cables pressing plate	1	
34	BoltST4X 14(female flange)	2	
35	Cable shield	1	
36	Cable conductor	1	