

Polymak®

PM-CAG-18VB-2B LITHIUM ANGLE GRINDER

Battery Voltage: 18V
 Battery Capacity: 4.0Ah
 Max. wheel diameter: 100mm
 No load speed: 11000r/min
 Net weight: 4.5KG

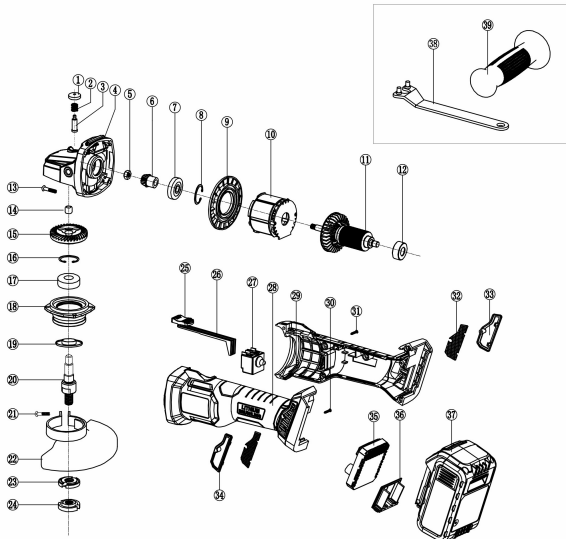

www.polymak.co.in

Polymak®

PM-CAG-18VB-2B SPARE PARTS LIST

No	Parts Name	Pcs	Seri No	INR	No	Parts Name	Pcs	Seri No	INR
1	M100BL Brake Cap	1			38				
2	Angle grinder 0.6 brake pin spring	1			39				
3	M100BL brake rod	1			40				
4	Aluminum head shell	1			41				
5	Guide ring	1			42				
6	M6 nut	1			43				
7	Brushless Angle grinder small umbrella teeth	1			44				
8	608VV bearing	1			45				
9	22 hole circlip	1			46				
10	Rotor of BLDCM	1			47				
11	BLDCM stator	1			48				
12	ST4*20 plum blossom pain head	4			49				
13	H60810 bearing	1			50				
14	Brushless Angle grinder large umbrella teeth	1			51				
15	M4*12 cross armor-head combination	4			52				
16	32 hole circlip	1			53				
17	6201 bearing pedestal bearing	1			54				
18	M100BL bearing Block	1			55				
19	9556HN principal axis dustproof ring	1			56				
20	100 Angle grinder shaft	1							
21	100 Protective cover 9525	1							
22	125 / 9523 inner pressing plate	1							
23	125 / 9523 external pressing plate	1							
24	M100BL push-block	1							
25	M100BL push-pull rod	1							
26	switch	1							
27	M100BL casing	1							
28	L/R screen trim cover	2							
29	Right screen trim cover	1							
30	ST4*16 plum blossom pain head	5							
31	Left screen trim cover	1							
32	801 stents	1							
33	M100BL control board	1							
34	Ak47 pins	1							
35	Battery pack	2							
36	Deputy hand	1							
37	ST3*6 plum blossom pain head	2							