

Polymak[®]

ELECTRIC MIXER

16mm

INSTRUCTION MANUAL

Polymak[®]

Polymak Tools(India)Pvt.Ltd

186/187, P.H Road,Alsa Towers,Kilpauk,
Chennai – 600 010,

Tel. : +91-44-48631869

E-mail : info@polymak.co.in

Visit us at : www.polymak.co.in



Read and follow all safety precautions in instruction manual.

Power Tool Safety Rules

! WARNING

Read and understand all instructions. Failure to follow all instructions listed below, may result in electric shock, fire and/or serious personal injury.

SAVE THESE INSTRUCTIONS

Work Area

Keep your work area clean and well lit. Cluttered benches and dark areas invite accidents.

Do not operate power tools in explosive atmospheres, such as in the presence of flammable liquids, gases, or dust. Power tools create sparks which may ignite the dust or fumes.

Keep by-standers, children, and visitors away while operating a power tool. Distractions can cause you to lose control.

Electrical Safety

Before plugging in the tool, be certain the outlet voltage supplied is within the voltage marked on the nameplate. Do not use "AC only" rated tools with a DC power supply.

Avoid body contact with grounded surfaces such as pipes, radiators, ranges and refrigerators. There is an increased risk of electric shock if your body is grounded. If operating the power tool in damp locations is unavoidable, a Ground Fault Circuit Interrupter must be used to supply the power to your tool. Electrician's rubber gloves and footwear will further enhance your personal safety.

Don't expose power tools to rain or wet conditions. Water entering a power tool will increase the risk of electric shock.

Do not abuse the cord. Never use the cord to carry the tools or pull the plug from an outlet. Keep cord away from heat, oil, sharp edges or moving parts. Replace damaged cords immediately. Damaged cords increase the risk of electric shock.

When operating a power tool outside, use an outdoor extension cord marked "W-A" or "W." These cords are rated for outdoor use and reduce the risk of electric shock.

Personal Safety

Stay alert, watch what you are doing and use common sense when operating a power tool. Do not use tool while tired or under the influence of drugs, alcohol, or medication. A moment of inattention while operating power tools may result in serious personal injury.

Dress properly. Do not wear loose clothing or jewelry. Contain long hair. Keep your hair, clothing, and gloves away from moving parts. Loose clothes, jewelry, or long hair can be caught in moving parts. Keep handles dry, clean and free from oil and grease.

Avoid accidental starting. Be sure switch is "OFF" before plugging in. Carrying tools with your finger on the switch or plugging in tools that have the switch "ON" invites accidents.

Remove adjusting keys or wrenches before turning the tool "ON". A wrench or a key that is left attached to a rotating part of the tool may result in personal injury.

Do not overreach. Keep proper footing and balance at all times. Proper footing and balance enables better control of the tool in unexpected situations.

Use safety equipment. Always wear eye protection. Dust mask, non-skid safety shoes, hard hat, or hearing protection must be used for appropriate conditions.

Tool Use and Care

Use clamps or other practical way to secure and support the workpiece to a stable platform. Holding the work by hand or against your body is unstable and may lead to loss of control.

Do not force tool. Use the correct tool for your application. The correct tool will do the job better and safer at the rate for which it is designed.

Do not use tool if switch does not turn it "ON" or "OFF". Any tool that cannot be controlled with the switch is dangerous and must be repaired.

Disconnect the plug from the power source before making any adjustments, changing accessories, or storing the tool. Such preventive safety measures reduce the risk of starting the tool accidentally.

Store idle tools out of reach of children and other untrained persons. Tools are dangerous in the hands of untrained users.

Maintain tools with care. Keep cutting tools sharp and clean. Properly maintained tools, with sharp cutting edges are less likely to bind and are easier to control. Any alteration or modification is a misuse and may result in a dangerous condition.

Check for misalignment or binding of moving parts, breakage of parts, and any other condition that may affect the operation. If damaged, have the tools serviced before using. Many accidents are caused by poorly maintained tools. Develop a periodic maintenance schedule for your tool.

Use only accessories that are recommended by the manufacturer for your model. Accessories that may be suitable for one tool, may become hazardous when used on another tool.

! WARNING

This tool is grounded tools must be plugged into an outlet properly installed and grounded in accordance with all codes and ordinances. Never remove the grounding prong or modify the plug in any way. Do not use any adapto plugs. Check with a qualified electrician if you are in doubt as to whether the outlet is properly grounded

Service

Tool service must be performed only by qualified repair personnel. Service or maintenance performed by unqualified personnel could result in a risk of injury. For example: internal wires may be misplaced or pinched, safety guard return springs may be improperly mounted.

When servicing a tool, use only identical replacement parts. Follow instructions in the Maintenance section of this manual. Use of unauthorized parts or failure to follow Maintenance Instructions may create a risk of electric shock or injury. Certain cleaning agents such as gasoline, carbon tetrachloride, ammonia, etc. may damage plastic parts.

PM16MD Electric Mixer Spare Parts List					
No	Name Of Parts	Qty	No	Name Of Parts	Qty
1	Mixer rod		21	Screw ST4*60	2
2	Spindle		22	Bearing Sleeve	
3	Key 4*5*13		23	Filed Coil	
4	Washer 40		24	Housing	
5	Dustproof washer		25	Name Plate	
6	Bearing 6203		26	Brush Holder	2
7	Washer 17		27	Carbon Brush	2
8	Screw ST5*35	4	28	Brush Holder cover	2
9	Gear Box		29	Back handle	
10	Big Gear		30	Screw ST4*14	8
11	Washer 14		31	Filed Coil Spring	2
12	Bearing 608	4	32	Light handle	
13	Gear shaft		33	Screw ST5*19	4
14	Key 3*3.7*10		34	Switch	
15	Small gear		35	Left Handle	
16	Washer 10		36	Screw ST4*14	2
17	Middle case		37	Cable Parts	
18	Guide air gasket		38	Cable Sleeve	
19	Bearing 6200		39	Cable	
20	Armature		40	Side Handle	

Safety Rules for Drills

Hold tool by insulated gripping surfaces when performing an operation where the cutting tools may contact hidden wiring or its own cord. Contact with a "live" wire will make exposed metal parts of the tool "live" and shock the operator. Do not drill, fasten or break into existing walls or other blind areas where electrical wiring may exist. If this situation is unavoidable, disconnect all fuses or circuit breakers feeding this worksite.

Wear ear protectors when using the tool for extended periods. Prolonged exposure to high intensity noise can cause hearing loss. Always use auxiliary handle for maximum control over torque reaction or kick-back. High torque 3/8" and larger chuck capacity drills are equipped with auxiliary handles.

Always wear safety goggles or eye protection when using this tool. Use a dust mask or respirator for applications which generate dust.

Use thick cushioned gloves and limit the exposure time by taking frequent rest periods. Vibration caused by hammer-drill action may be harmful to your hands and arms.

Secure the material being drilled. Never hold it in your hand or across legs. Unstable support can cause the drill bit to bind causing loss of control and injury.

Never leave the trigger locked "ON". Before plugging the tool in, check that the rigger lock is "OFF". Accidental start-ups could cause injury.

Position the cord clear of rotating bit. Do not wrap the cord around your arm or wrist. If you lose control and have the cord wrapped around your arm or wrist it may entrap you and cause injury.

Position yourself to avoid being caught between the tool or side handle and walls or posts. Should the bit become bound or ammed in the work, the reaction torque of the tool could crush your hand or leg.

If the bit becomes bound in the workpiece, release the trigger immediately, reverse the direction of rotation and slowly squeeze the trigger to back out the bit. Be ready for a strong reaction torque. The drill body will tend to twist in the opposite direction as the drill bit is rotating.

Do not grasp the tool or place your hands too close to the spinning chuck or drill bit. Your hand may be lacerated.

Do not use the switch "Lock-ON" feature in situations where drill bit binding is likely. (For example: just before the bit is ready to break through the material, anytime when using a "Hole Saw", auger bits..... etc.) When the bit binds, the drill's body will twist or kick-back in opposite direction and the release of the trigger "Lock-ON" may be difficult.

Be aware of the location and setting of the switch "Lock-ON" button. If the switch is locked "ON" during the use, be ready for emergency situations to switch it "OFF", by first pulling the trigger then immediately releasing it without pressing the "Lock-ON" button.

When installing a drill bit, insert the shank of the bit well within the jaws of the chuck. If the bit is not inserted deep enough, the grip of the jaws over the bit is reduced and the loss of control is increased.

Do not use dull or damaged bits and accessories. Dull or damaged bits have a greater tendency to bind in the workpiece.

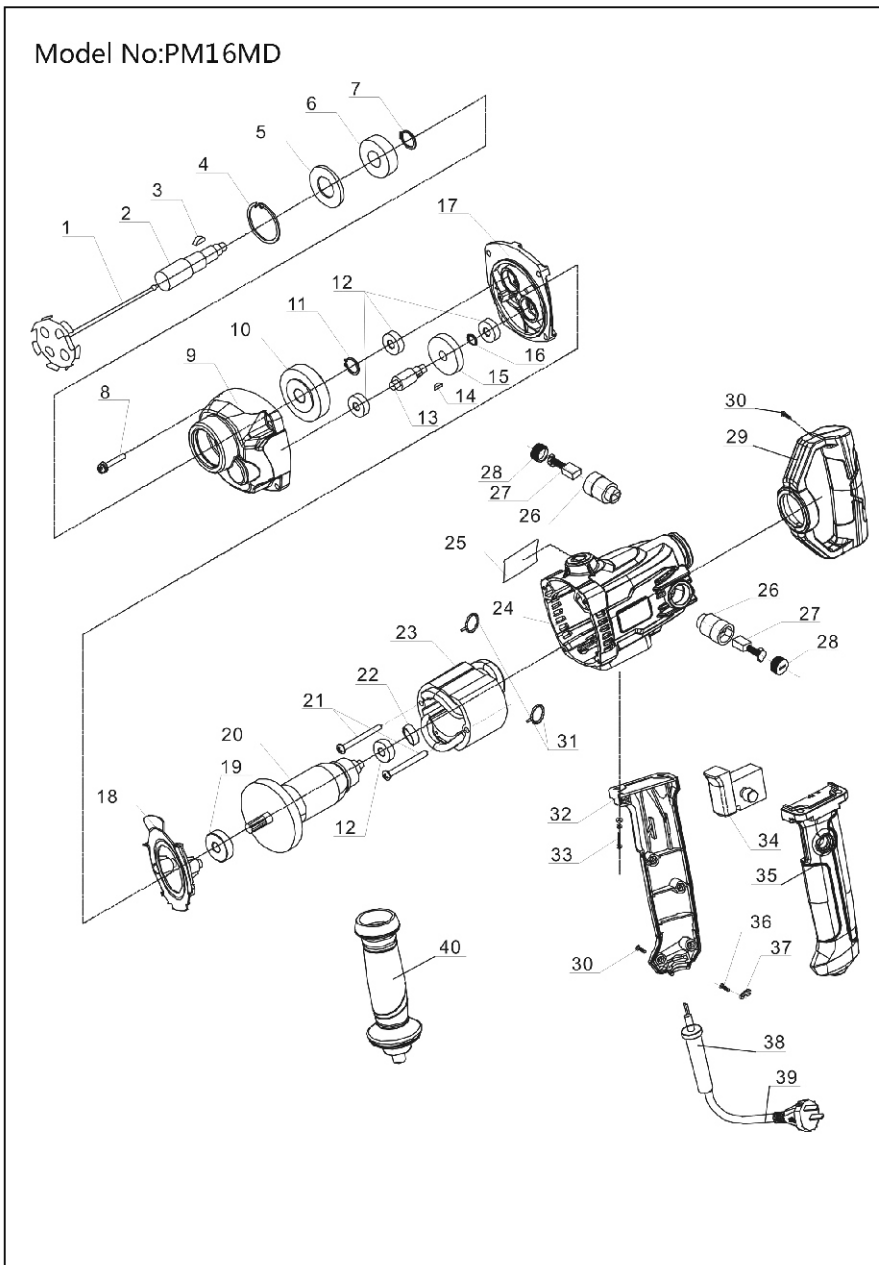

When removing the bit from the tool avoid contact with skin and use proper protective gloves when grasping the bit or accessory. Accessories may be hot after prolonged use.

Check to see that keys and adjusting wrenches are removed from the drill before switching the tool "ON". Keys or wrenches can fly away at high velocity striking you or a bystander.

Do not run the drill while carrying it at your side. A spinning drill bit could become entangled with clothing and injury may result.

This tool may be used with sanding and polishing disks, grinding wheels, air wheel and wire cup brushes. These accessories must be rated for at least the speed recommended on the tool warning label. Wheels and other accessories running over rated speed can fly apart and cause injury.

! WARNING

Some dust created by power sanding, sawing, grinding, drilling, and other construction activities contains chemicals known to cause cancer, birth defects or other reproductive harm. Some examples of these chemicals are:

- Lead from lead-based paints,
 - Crystalline silica from bricks and cement and other masonry products, and
 - Arsenic and chromium from chemically-treated lumber.
- our risk from these exposures varies, depending on how often you do this type of work. To reduce your exposure to these chemicals: work in a well ventilated area, and work with approved safety equipment, such as those dust masks that are specially designed to filter out microscopic particles.

SYMBOLS

IMPORTANT: Some of the following symbols may be used on your tool. Please study them and learn their meaning. Proper interpretation of these symbols will allow you to operate the tool better and safer.

Operating Instructions

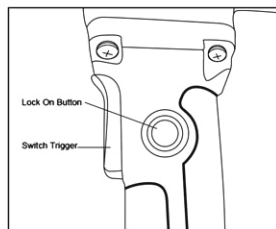

"LOCK-ON" BUTTON

The "Lock-ON" button, located in the handle of your tool allows for continuous operation at maximum RPM without holding the trigger.

TO LOCK TRIGGER "ON": squeeze trigger, depress button and release trigger.

TO UNLOCK THE TRIGGER: squeeze trigger and release it without depressing the "Lock-ON" button.

! WARNING

If the "Lock-ON" button is continuously being depressed, the trigger can not be released.

! CAUTION

Do not change direction of rotation until the tool comes to a complete stop. Shifting during rotation of the chuck can cause damage to the tool.

Maintenance

Service

! WARNING

Preventive maintenance performed by unauthorized personnel may result in misplacing of internal wires and components which could cause serious hazard. We recommend that all tool service be performed by a Factory Authorized Service Station.

Tool Lubrication

Your tool has been properly lubricated and is ready to use. It is recommended that tools with gears be regreased with a special gear lubricant at every brush change.

Carbon Brushes

The brushes and commutator in your tool have been engineered for many hours of dependable service. To maintain peak efficiency of the motor, we recommend every 50 hours of operation the brushes be examined. Only genuine replacement brushes specially designed for your tool should be used.

Bearings

After about 50 hours of operation, or at every second brush change, the bearings should be replaced at Factory Authorized Service Station. Bearings which become noisy (due to heavy load or very abrasive material cutting) should be replaced at once to avoid overheating or motor failure.

Cleaning

! WARNING

To avoid accidents always disconnect the tool from the power supply before cleaning or performing any maintenance. The tool may be cleaned most effectively with compressed dry air. Always wear safety goggles when cleaning tools with compressed air. Ventilation openings and switch levers must be kept clean and free of foreign matter. Do not attempt to clean by inserting pointed objects through openings.

Specification:

Electric Mixer	
Voltage/Frequency:	220V/50Hz
Power:	880W
No load speed:	750r/min
Spindle size:	12mm(M12)
Weight	2.1kg
Protection class	□ / II