

# Polymak®

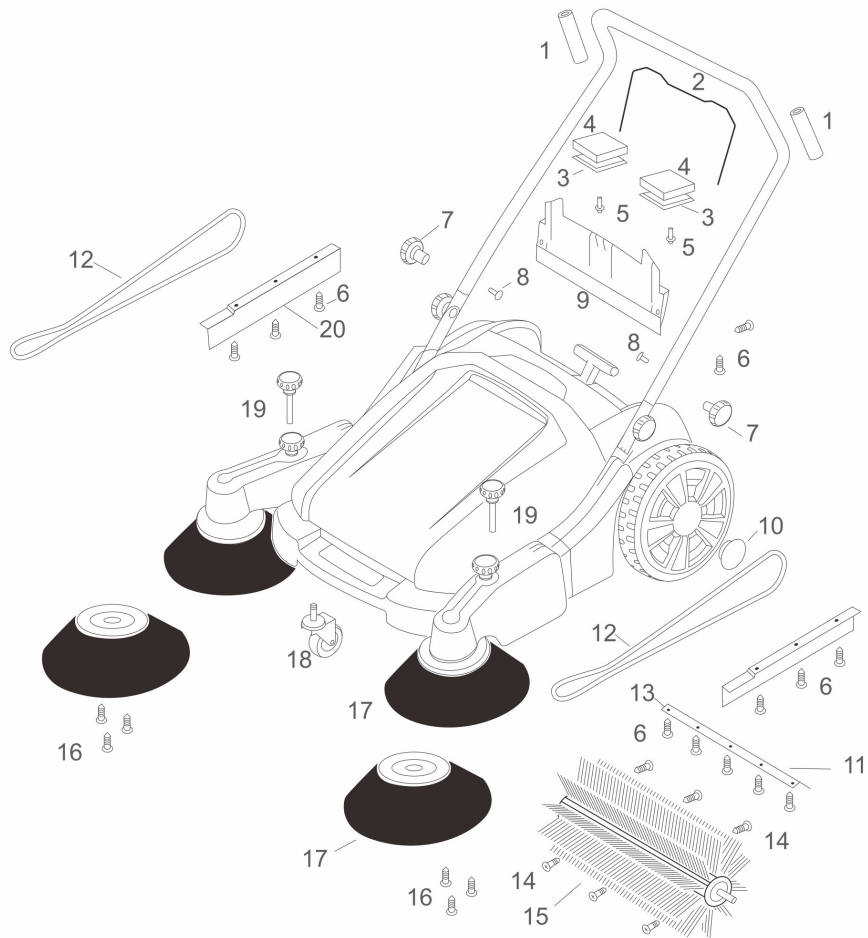

**PMFS50L** HAND PUSH SWEEPING MACHINE

Container capacity:	50L
Speed:	3kph Area
Swept:	4000msq.ft
Operating width:	980mm



# Polymak®

## PMFS50L SPARE PARTS LIST

No	Parts Name	Pcs	Seri No	INR	No	Parts Name	Pcs	Seri No	INR
1	Handle Soft Roll								
2	Sealing Strip								
3	Sponge Cover								
4	Sponge								
5	Screw								
6	Screw ST4.8x16								
7	Handle								
8	Screw M8x25								
9	Fender								
10	Tier Cover								
11	Fender								
12	Drive Belt								
13	Dustproof Sponge								
14	Screw ST4.8x32								
15	Main Brush Set								
16	Screw ST4.8x22								
17	Front Brush								
18	Adjust Knob								
19	Adjust Knob Set								
20	Fender								
21									
22									
23									
24									
25									
26									
27									
28									
29									
30									
31									
32									
33									
34									
35									
36									
37									